

RADIANT MOBILE

# RADIANT MOBILE

MODEL NO: 10070X01

Hand poured, rippled glass crystal puddles suspended on custom-machined hardware and rigid, linear structure, illuminated by integrated, refracting light.

## AS SHOWN (IN PHOTO)

6 glass pieces, 3 tiers - approx. dimensions 60"W x 60"D x 31"H  
Glass - clear with iridescence  
Metal - oil rubbed blackened steel

## DIMENSIONS

Available in four sizes:

4 glass pieces, 2 tiers - approx. dimensions 48"W x 48"D x 18"H  
4 glass pieces, 2 tiers - approx. dimensions 72"W x 36"D x 18"H  
6 glass pieces, 3 tiers - approx. dimensions 60"W x 60"D x 31"H  
6 glass pieces, 3 tiers - approx. dimensions 84"W x 48"D x 31"H

Glass - large approx. 12.5"W x 11.5"D x .75"H  
small approx. 11"W x 10"D x .75"H

Glass dimensions may vary slightly due to hand poured process

## ELECTRICAL

Integrated LED  
2700K, 2W per glass, 50,000hrs average life  
Driver onboard  
120-277VAC universal input  
Dimmable: Triac, ELV, 0-10V  
Requires 4" x 2-1/8"D octagon junction box

## AVAILABLE FINISHES

Glass Crystal Color - clear

Glass Crystal Finish - standard or with iridescence

Metal - oil rubbed blackened steel, light oil rubbed blackened steel, burnished silver, brushed silver, brushed brass\*, oxidized brass\*

\*premium finish - refer to price guide for additional charges

## ADDITIONAL NOTES

General lead time for standard finishes is 8-10 weeks. Updated lead times provided at time of formal quoting. This fixture has minimum OAD requirements - refer to price guide for additional information. Covered by EU, UK, and Chinese design registrations.

UL listed



4 PIECE, 2 TIER 48"W x 48"D x 18"H

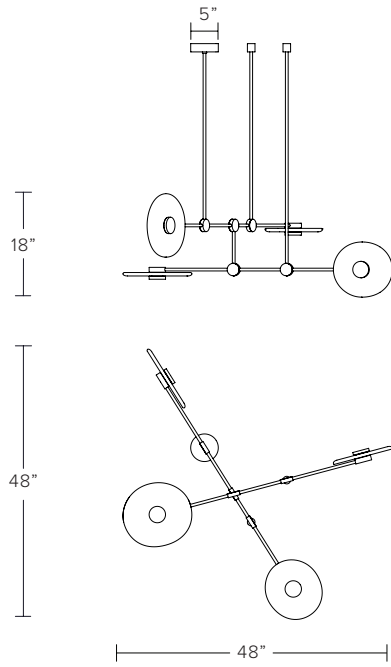

4 PIECE, 2 TIER 72"W x 36"D x 18"H

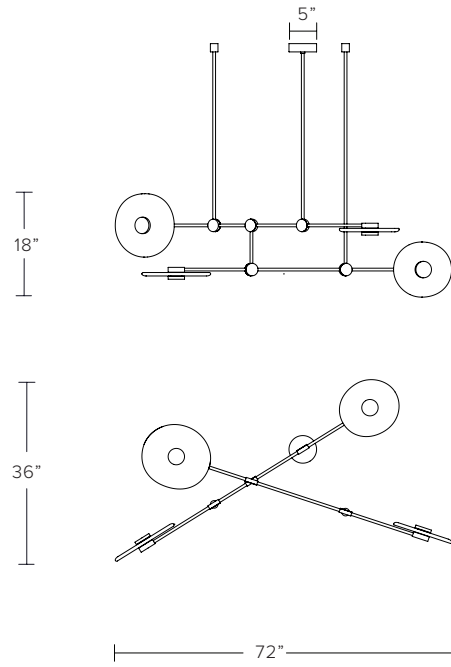

6 PIECE, 3 TIER 60"W x 60"D x 31"H

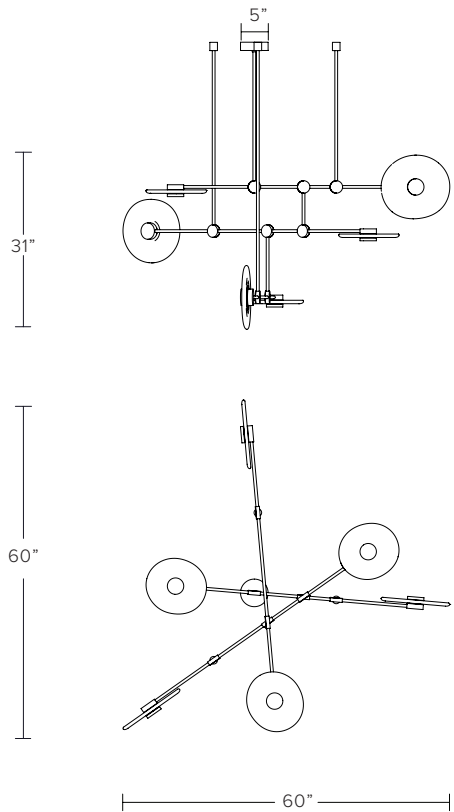

6 PIECE, 3 TIER 84"W x 48"D x 31"H

